

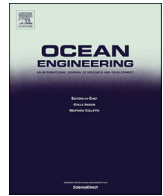

Contents lists available at ScienceDirect

# Ocean Engineering

journal homepage: [www.elsevier.com/locate/oceaneng](http://www.elsevier.com/locate/oceaneng)

## Review

# Pipelines, risers and umbilicals failures: A literature review

Geovana P. Drumond<sup>\*</sup>, Ilson P. Pasqualino, Bianca C. Pinheiro, Segen F. Estefen

Subsea Technology Laboratory, COPPE, Federal University of Rio de Janeiro, Brazil

## ARTICLE INFO

### Keywords:

Equipments failures  
Deepwater  
Oil and gas industry

## ABSTRACT

The exploratory frontier of offshore oil and gas industry comes into deeper waters, with the 3000 m water depth barrier hurdled in the US Gulf of Mexico in 2003. At these water depths, the extremely high external pressures, low temperatures, long distance tie-backs and high environmental loads due to waves, currents, and wind combined brings the employed equipment to its operational limit. This paper presents a literature review on failure events experienced by the industry concerning pipelines, risers, and umbilical cables, describing their causes, consequences, and severity. From the several failure modes reported up to now, it is possible to select the ones that are more frequent and deserves attention from academia and industry. Concerning pipelines, the main failure modes reported are due to mechanical damage, corrosion, construction defect, natural hazards and fatigue. Additionally, a vast review of published researches concerning the pipeline-seabed interaction is presented. With regard to floating risers, approximately 85% of them are of flexible type. Although flexible risers may fail in different ways, collapse due to external pressure is reported as the most frequent failure mode. For umbilical cables, the major failure modes are found to occur under tension or compression, torsion, fatigue, wear and sheaving.

## 1. Introduction

Oil and gas exploration and production in deepwater is associated with the use of highly sophisticated equipment and increasing innovative technology. However, the failure of this equipment can cause serious consequences, including material loss and environmental pollution. Critical accidents can even cause the loss of human lives. Based on a literature review, this paper aims to identify past typical failures experienced in the industry concerning pipelines, risers, and umbilicals, detailing the causes, consequences, and severity of these failures.

Pipelines are the safest method to export liquid and gaseous petroleum products or chemicals (Roche, 2007). However, like any engineering structure, pipelines do occasionally fail. The main failure modes experienced by pipelines during production are identified as mechanical damage (impact or accidental damage), external and/or internal corrosion, construction defect, material or mechanical failure, natural hazards and fatigue.

Risers are oil and gas transfer lines of much importance to offshore oil and gas production systems. They comprise the dynamic segment of an exportation pipeline or a production flowline connecting seabed to the production unit at sea level. They are affected by mechanical stress, environmental issues and individual conditions resulting from the

geographic location where the production unit has been installed. Risers can be classified as flexible or rigid. For flexible risers, the major failures experienced are due to fatigue, corrosion, torsion, burst, collapse and overbending. For rigid risers, the most common external threats are impacts, internal and/or external corrosion, overstress, fatigue, structural wear, structural instability, material degradation and fire/explosion (in surface segments).

Umbilical cables are responsible to control subsea equipment like Xmas trees, manifolds, pumps, separators, etc. Bryant (1990) identifies the failure modes of umbilical cables as tension or compression, torsion, fatigue, wear and sheaving. These failures modes are discussed with particular focus on sheaving, which is associated with the use of static sheaves, such as curved plates during umbilical installation.

This work is motivated by the need of extensively address studies about the safety of offshore operations in deepwater and ultra-deepwater scenarios, like pre-salt fields in the Brazilian Santos Basin. The compiled information can be used as a guide to initiate studies on structural integrity. The possibility of contributing to the establishment of a national program of offshore safety in Brazil, with emphasis on technological advances that aim the prevention of accidents, is also a motivation for this research.

<sup>\*</sup> Corresponding author.

E-mail address: [geovana@lts.coppe.ufrj.br](mailto:geovana@lts.coppe.ufrj.br) (G.P. Drumond).

## 2. Pipeline failures

According to the US Pipeline & Hazardous Materials Safety Administration (PHMSA, 2014), there were a few more than three hundred offshore pipeline incidents in the U.S. in the past ten years, seventy one involving hydrocarbon releases (Aljaroudi et al., 2015).

Pipeline failures are usually related to a breakdown in the system, for example, the loss of corrosion protection, meaning a combination of ageing coating, aggressive environment, and rapid corrosion growth that may lead to a failure. This type of failure is not simply a corrosion failure, but a corrosion control system failure. Similar observations can be drawn for failures due to external interference, stress corrosion cracking, etc. (Cosham and Hopkins, 2002).

Based on four different databases that include only accidents that led to loss of containment, De Stefani and Carr (2010) pointed out the following as the most probable failure modes in pipelines: mechanical damage (which includes impact and any external damage), external or internal corrosion, construction defect, mechanical or material failure, and natural hazards. Stadie-Frohbs and Lampe (2013) also studied offshore pipeline failures. Based on existing codes as DNV-RP-F116 (2009) and historical records considering 22 offshore pipelines, the authors concluded that beside the failure modes mentioned above, erosion, structural threats (fatigue and static overloads, particularly at free spans) and unpredicted operation are also possible failure modes.

Based on pipeline and riser loss of containment (PARLOC, 2003) and data from PHMSA (2014), Stadie-Frohbs and Lampe (2013) concluded that impact is the major cause of failures in offshore pipelines in operation at North Sea, representing 56% of the total failures between 1971 and 2000. In the US, comparing all failures reported between 1995 and 2011, 31% are caused by corrosion. These numbers and those of other failure causes are summarized in Fig. 1.

The difference between the two scenarios (US and North Sea) may be explained by geographic reasons. At the shallow waters of North Sea, the impact of a dropped object is most probably than at US deepwaters, since the current action can deviate the object from the undesirable target. On the other hand, hurricanes are frequent at US, increasing the failures by natural hazards at those fields. Anyway, corrosion is always an issue of concern for both scenarios.

Review and analysis of historical causes of pipeline failures

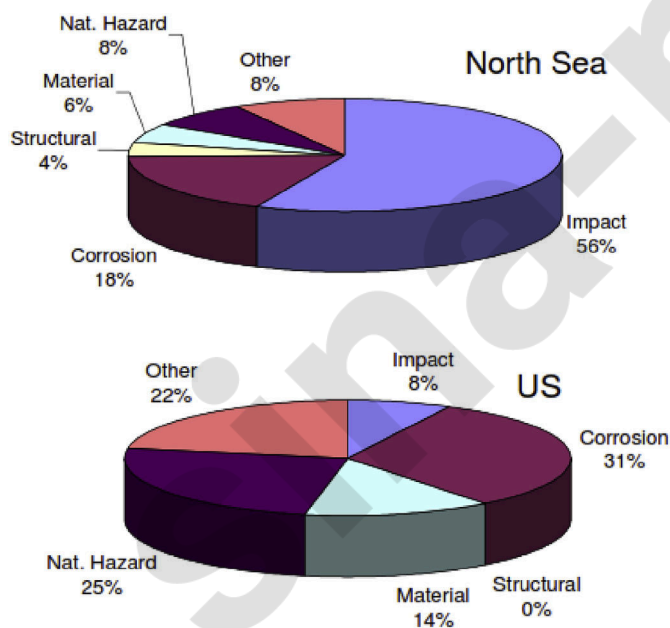

Fig. 1. Offshore pipeline failures (Stadie-Frohbs and Lampe, 2013).

worldwide indicate that corrosion, especially internal corrosion, is the most widely reported cause of failure of offshore pipelines, followed by maritime activities (anchor or trawling damage and vessel collisions), and natural forces like storms and mudslides (Hokstad et al., 2010).

Corrosion reduces the pipeline's strength and capacity to endure operating pressure leading to two possible failure events: leakage or burst. Leakage failure occurs when corrosion fully penetrates the pipeline wall thickness, while burst failure occurs when operating pressure exceeds the maximum allowable pressure at a defect point (Aljaroudi et al., 2015). All internal and external corrosion occurrences affecting pipelines used in the oil & gas industry are of electrochemical nature, i.e. they need the presence of water in contact with steel and oxidizing species dissolved in water for feeding corrosion cells (Roche, 2007). At ultra-deepwater scenarios, thickness reduction can cause collapse under external pressure rather than burst under internal pressure.

Cathode protection (CP) and coatings are used to protect offshore transportation pipelines. According to Roche (2004), as long as coatings remain bonded to steel and cathode protection is correctly applied, monitored and maintained, no external corrosion risk exists. However, the same author, in another paper published three years later, stated that not even the risk of corrosion under unbonded coating is a concern to offshore pipelines integrity. This is probably due to the high conductivity and homogeneity of seawater, which makes easier the access of CP current underneath electrical shields (Roche, 2007).

According to Roche (2007), most of the leaks due to internal corrosion have been explained by microbiologically Induced corrosion (MIC) or by ingress of CO<sub>2</sub> traces combined with H<sub>2</sub>S. The first parameter determining corrosion risks is the presence of water in contact with steel surfaces. This contact is obvious for injection water lines. In the case of oil pipelines, water may be in contact with steel at the bottom of the pipe, settled by gravity, and on the flow pattern, depending on the water content. For wet gas pipelines, water is separate also at the pipeline bottom line, but in some cases condensation may occur if the gas is hot at the top line when cooling from outside is significant enough. Several types of corrosion may occur at locations where water is in contact with steel as long as oxidizing species are present. The most frequent species are CO<sub>2</sub>, light organic acids, H<sub>2</sub>S and O<sub>2</sub>. Most often, corrosion pattern is in the form of pits, craters or more uniform wall thinning.

In India offshore facilities, premature leaks in subsea water injection pipelines due to rupture were observed. Analysis of different operating parameters and water quality indicated failure due to microbial induced internal corrosion. According to Samant and Singh (1998), this kind of corrosion was due to low flow velocities, insoluble corrosion products suspended, iron oxide, iron sulfide, and bacteria present in the water accumulated at the bottom of the pipe. Moreover, non-pigging of the pipeline might have allowed bacteria to multiply rapidly and develop colonies and biofilm, which provides a hiding sites for bacteria and shielded them from effective treatment by bactericides. Due to lack of frequent pigging and an effective microbiocidal treatment procedure, the uncontrolled growth of bacteria occurred. Consequently, microbial activities dominated and led to an acidic environment that ultimately caused internal severe localized corrosion (Samant and Singh, 1998).

Another pipeline failure case was reported by Rose (1999) and was attributed to girth weld problems. At Point Pedernales field, California, a complete and sudden failure of a subsea pipeline caused the release of 163 barrels of crude oil into the Pacific Ocean. A crack occurred at a girth weld between pipe body and the flange bell. After investigation and analysis of the failure, it was concluded that the crack initiated at the heat-affected zone leading to a complete separation of the flange bell. The examination revealed that the heat-affected zone was brittle, possibly due to a lack of preheating prior to welding. Therefore, numerous microcracks have developed, one of which being the failure initiation site (Rose, 1999).

Amend (2010) attributed to welds the responsibility for more than 6% of significant pipeline failures. The author stated that pipeline girth welds are unlikely to fail unless subjected to axial strains that far exceed

the strains related to internal pressure alone. Girth welds containing significant workmanship flaws are likely to be resistant to failure at stresses less than the pipe yield strength, unless the welds do not match specification and/or are susceptible to brittle fracture initiation.

Pipe buckling and overbending can result from longitudinal compressive stresses induced by a change of temperature (Simonsen, 2014). If the temperature of a pipeline is increased, due to a production fluid flow temperature, the pipeline can deform both circumferentially and axially. Circumferential expansion is usually fully unconstrained, but longitudinal expansion is often prevented by seabed friction and attachments, generating compressive stresses that can lead to pipe buckling and overbending.

A vast review of published researches on the pipeline-seabed interaction under waves and/or currents is presented by Fredsøe (2016), comprising three issues: scour, liquefaction, and lateral stability of pipelines.

The process of scour around a pipeline is dependent on seabed interaction, which is influenced by pipeline movement due to bending along the scour process (Fredsøe, 2016). When the pipe is placed on or slightly embedded a certain distance  $e$  from the seabed, piping may occur due to its submerged weight by the seepage flow below it (Fredsøe, 2016). Such flow is caused by the pressure difference between the upstream stagnation pressure (Point A in Fig. 2) and the lower pressure in the leeside wake (Point B in Fig. 2). As described by Sumer et al. (2001), the pressure gradient from A to B (Fig. 2) is a function of the Keulegan–Carpenter number  $KC$  for waves, defined as

$$KC = 2\pi a/D \quad (1)$$

where  $a$  is the orbital amplitude.

In steady flow, the wake pressure is primarily governed by the pressure in the separation point (Point S in Fig. 2), which is slightly lower due to the small velocities in the wake compared to the outer flow. In S, the pressure is low since the outside flow is high. The scour process initiated by piping was studied experimentally by Chiew (1990) and Sumer et al. (2001). The onset of the scour beneath a pipeline strongly depends on the initial embedment  $e$  into the seabed. An upper limit was found for the onset of scour when the pipe is embedded. No onset was observed by Chiew (1990) when  $e/D$  exceeded 0.5, where  $D$  is the pipe diameter. The scour process in the onset of piping in waves is similar to that in the current-alone case, with some particularities since the flow attack is bidirectional.

The impact of the length of the scour hole on the pipeline deformation was studied by Leckie et al. (2015) and Draper et al. (2015). They found that for long holes, the pipe locally sags down into the hole, causing strains along the pipe, while for shorter holes, the pipe sinks more uniformly.

A scoured hole around a pipeline may further undergo sediment backfilling, which can be caused, for instance, by the touchdown of the pipe into the scoured hole. This backfill process was observed experimentally by Sumer and Fredsøe (2002). The development of scour holes along the pipe affects the sinking velocity of the pipe into the bed: faster spreading of the holes is related to faster pipe sinking.

When the pipe is located in a free span, it may vibrate as a result of waves and/or current (Sumer et al., 1989; Shen et al., 2000; Zhao and

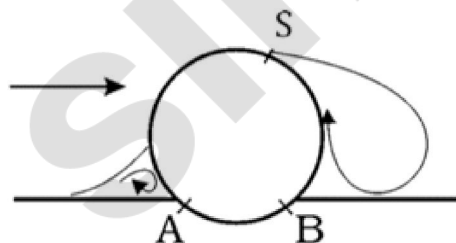

Fig. 2. Vortex system around an embedded pipeline exposed to a current Fredsøe (2016).

Cheng, 2010), which causes an additional pulsating flow around the pipe, leading to an expansion of the scoured-bed profile.

A mechanism to stop the expansion of the scour hole along the pipe is the increased embedment of the pipe in the shoulders, which considerably reduces the scour below the pipe in the free span. Scour can be reduced or totally avoided by installing flexible mattresses around it, placed either above or beneath the pipe. The horizontal extent away from the pipe must be sufficient large, so the edge scour at the outer periphery is sufficiently reduced to ensure the mat's stability (Fredsøe, 2016).

Noncohesive soil in the seabed exposed to waves may undergo liquefaction, when pipelines placed on the seabed may sink if their submerged density is higher than the liquefied soil density. Similarly, buried pipelines may float to the bed surface when their submerged density is lower than that of the surrounding liquefied soil (Fredsøe, 2016). Usually, liquefaction caused by earthquake is the major cause for liquefaction of soil due to its large amplitude in the oscillation and higher frequency (Fredsøe, 2016). Waves can also cause liquefaction (Jeng, 2013; Sumer, 2014).

Regarding the lateral stability of pipelines, Wagner et al. (1989) developed a model to predict the soil resistance to lateral motions of untrenched submarine pipelines, including loading history effects to the Coulomb friction model. They conducted full scale laboratory tests of pipe-soil interaction, including both monotonic and cyclic lateral load tests, on five offshore soil conditions: loose silty fine sand, loose medium/coarse sand, dense medium/coarse sand, soft clay and stiff clay. The tests showed that any loading history that causes increased pipe penetration resulted in increased lateral resistance, and this dependence is not addressed by the typical Coulomb model. A two-term empirical lateral soil resistance model, which depends on the pipe size and weight, the soil strength, and the lateral loading history was then developed by Wagner et al. (1989):

$$F_H = F_F + F_R \quad (2)$$

where  $F_H$  is the total lateral soil resistance,  $F_F$  is the sliding resistance and  $F_R$  is the lateral passive soil resistance term.

In terms of flow-pipe-soil interaction mechanism, the works of Gao et al. (2002, 2007), and Teh et al. (2003) show advances in this area. Gao et al. (2002) adopted a hydrodynamic loading method to better understand the physics of lateral stability of untrenched offshore pipelines under wave loading. From the conduction of a series of experiments, the authors identified three characteristic stages in the process of pipe lateral instability: (a) onset of sand scour; (b) pipe rocking, and (c) pipe breakout. The authors established a linear relationship between the pipe weight parameter ( $G$ ) and hydrodynamic parameters ( $F_{Tb}$ ) by means of an empirical formula that works as a guide for engineering practice.

More recently, Gao et al. (2007) compared the results previously shown for the pipeline stability in waves with those in currents. This comparison is summarized in Fig. 3, where it can be noticed that under wave loading, after the fully stable stage, a slight rocking stage of the pipeline takes place. The time durations of both stages are approximately the same. Finally, in the last stage, the pipeline suddenly moves back and forth with large horizontal displacements, i.e., the pipe loses lateral stability (Fig. 3(a)). However, under the current loading, the pipe pushes the soil nearby ahead with a slight lateral displacement in the stream direction, instead of with slight rocking, after the totally stable stage. In the stage of the pipeline losing stability, the pipeline in the currents moves with large displacements only in the stream direction (Fig. 3(b)). Regarding the linear relationship between the pipe weight parameter and hydrodynamic parameters, developed by the authors in 2002, different relationships for pipeline lateral stability in waves and in currents were found, indicating that the pipeline directly laid on the sandy seabed in currents remains more stable than in waves for the same level of flow velocity.

The influence of the flow-pipe-soil interaction in the stability process was studied by Teh et al. (2003), which identified that, even if the

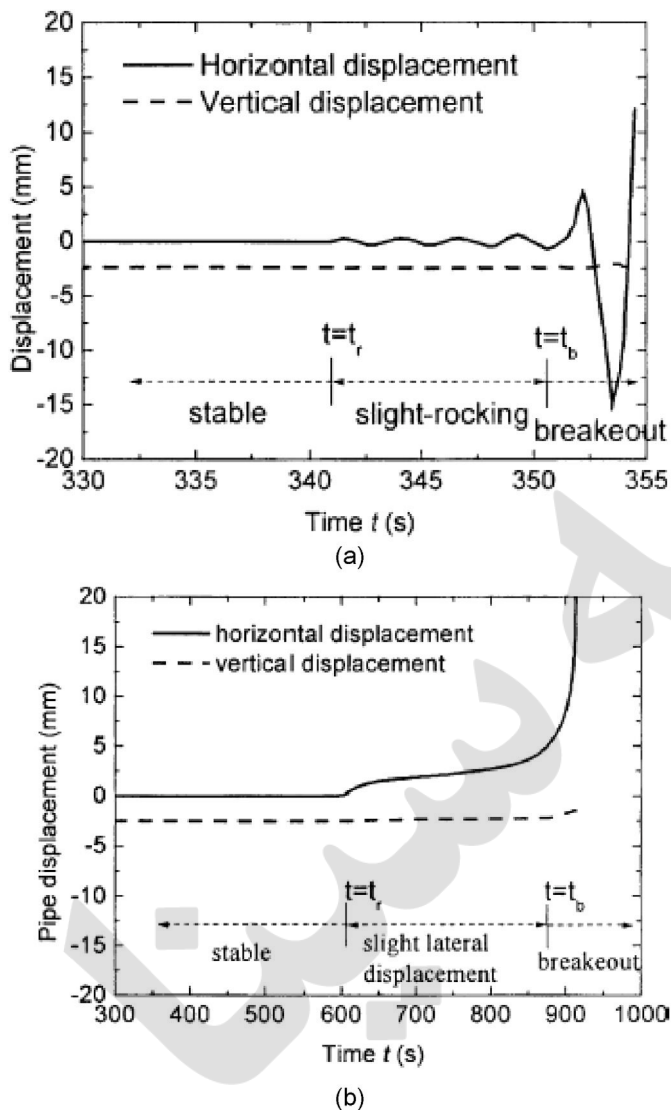

Fig. 3. Typical pipe displacement-time curves: (a) in waves; (b) in currents (Gao et al., 2007).

conventional design practice uses to assume the seabed itself as stable, there is substantial field evidence that assumption may be incomplete for erodible seabed under severe wave condition. The authors carried out a series of experiments to understand the behavior of a marine pipeline on a mobile and liquefied seabed. Two instability mechanisms were identified, depending on the specific gravity of the pipelines. If the pipeline is light enough, it tends to become unstable earlier than the seabed does, while if it is heavy enough, the instability should be first reached by the seabed. The results also showed that the pipeline sinking or floating depth in liquefied seabed depends on the pipeline specific gravity and liquefied soil parameters, but not on the wave condition.

### 3. Riser failures

Subsea risers are a type of flowline developed for the vertical transportation of fluids or products from the seafloor to production and drilling facilities above the water surface, as well as in the opposite way, from the facility to the seafloor for injection purposes. These conduits primarily transport produced hydrocarbons, but also make the transportation of injection fluids, control fluids and gas lift. Risers can be either rigid or flexible. During operations, these structures are susceptible

to dynamic loads that can lead to failures. The possible failure modes and some real incidents for each type of riser will be thoroughly discussed next.

Due to its importance to oil and gas production, a riser structural failure can lead to serious financial losses to operator. It results in reduction or cessation of revenue by committing the production development; it may also lead to spillage and pollution and may even endanger lives (Sen, 2006).

Cook et al. (2006) based their studies on BP's deepwater floating production facilities located in the Gulf of Mexico (GoM) and developed an integrity management study for a range of riser types: top-tensioned vertical risers, steel catenary risers and flexible pipe risers. The following most probable external threats for risers were determined considering the deepwater environment in the GoM: impacts, external corrosion, overstress, fatigue, wear, material degradation and fire/explosion (in above-water sections). Among these external threats, external corrosion is the most frequent. Another author, Anunobi (2012), stated that external corrosion is responsible for 70% of reported riser failure incidents.

#### 3.1. Rigid risers

The most severe consequences of a riser failure are typically associated with production/export/injection risers. There are many riser configurations to these functions but vertical top-tensioned rigid risers are historically most applied for production (Nazir et al., 2008). According to Hokstad et al. (2010), approximately 15% of risers for floating systems worldwide are metallic risers. Inside this percentage, 75% are top tensioned risers (TTRs), which are considered a mature technology that has been used for production since 1975 (MCS, 2009). This type of riser works as a conduit from the seabed to the facility and allows workover activity when it is necessary. TTRs are subjected to fatigue loads due to platform motions and ocean currents (Thethi et al., 2005).

In 2009, the MCS Advanced Subsea Engineering prepared an investigation into the causes and probabilities of top-tensioned riser (TTR) failures due to workover and drilling operations. Existing single and dual casing production risers with a surface blowout preventer were then analyzed (MCS, 2009). For sidetrack and re-drilling operations, the most critical riser failure modes outside of typical production hazards included drilling-induced vibration (DIV) fatigue, and riser wear from direct contact with the drill string. In both failure modes, reduced thickness caused by production represents a major contributing factor for their occurrence. If not noticed at the beginning, DIV can reduce drastically riser life or even lead to a complete failure of the riser.

A top-tensioned riser case study in the GoM is presented in the Recommended Practice DNV-RP-F206 (2008), in which are shown examples of possible failure mechanisms and their global failure modes. As system failure modes can be listed: burst, collapse, buckling with external and internal pressure, leakage, fracture due to fatigue and rupture due to overload. As major causes of failures can be listed: excessive pressure, excessive temperature, corrosion leading to critical material loss, excessive tension, excessive bending moment, excessive fatigue loading, physical damage by accident or during installation, and manufacturing defects. These failure mechanisms and failure modes are illustrated in Table 1.

Steel Catenary Risers (SCRs) are composed by a single wall rigid steel pipe and require minimal subsea equipment, which makes it cheaper than other configurations (Buberg, 2014). A SCR is a seemingly relatively simple system where the riser is in continuity with the flowline and is made up from welding a number of steel pipe joints of standard length (Quintin et al., 2007).

SCRs are not widely used but they are a very attractive option for deepwater operations because these risers have the advantage of being highly resistant to internal and external pressure. However, in terms of fatigue failure, these risers deserve careful evaluation of the fatigue life since they are very sensitive to cyclic loadings (Sen, 2006). In their study,

**Table 1**  
Examples of rigid riser failures: failure mechanism – initial cause – system failure modes (MCS, 2009).

Failure Mechanism	Initial Cause	Possible System Failure Modes
External corrosion	Cathodic protection failure	Burst
		Collapse
		Buckling with external pressure
		Buckling with internal Pressure
		Fracture
Internal corrosion	Production tubing leak	Rupture
		Burst
		Collapse
		Buckling with external pressure
		Buckling with internal pressure
Internal cracking	Sour fluid	Fracture
		Rupture
		Fracture
Pipe deformation	Accidental impact	Collapse or buckling
	Excessive external pressure	Collapse or buckling
	Bending moment	Collapse or buckling
Fatigue	Accidental impact	Fracture
	Production tubing leak	Fracture
Overload	Tensioner failure	Rupture or buckling
	Excessive internal pressure	Burst
Wear	Workover or drilling	Burst
		Collapse
		Buckling with external pressure
		Buckling with internal pressure
		Fracture
		Rupture

Kimiaei et al. (2010) stated that two critical fatigue areas could be highlighted in a SCR: the vessel hang-off point and the touchdown point, where the highest bending moment is observed. According to Sen (2008), the main contributors to fatigue damage are: (i) first order vessel motion, (ii) slow-drift, (iii) vortex induced vibration (VIV) and (iv) fatigue during transportation.

A case study of a steel catenary riser in West Africa is presented in the Recommended Practice DNV-RP-F206 (2008), and the results for initial cause, mechanism and failure modes are outlined in Table 2.

### 3.2. Flexible risers

As an alternative for conventional rigid steel pipes, flexible risers have been used over the last 30 years (Simonsen, 2014). The use of these

**Table 2**  
Initial cause, failure mechanism & failure modes (MCS, 2009).

SCR Sub-Component	Initial Cause (Root Cause)	Failure Mechanism	Possible Failure Modes
Riser pipe	Excessive internal pressure	Crack initiation, high SCF, fatigue	Leakage, burst, fracture, rupture
	Process fluid out of design	Internal metal loss due to corrosion, crack	Leakage, fracture, collapse, burst
	CP failure	External corrosion, localized pitting	Burst, collapse, fracture, rupture
Flexible joint	Marine growth	VIV suppression device failure	Leakage, fracture
	VIV	Fatigue	Leakage, fracture
	Ozone attack on elastomer	Elastomer cracking, flexible joint leakage, improper rotational stiffness, high bending moment, crack initiation	Fracture, rupture due to contact/wear between floater and SCR
	Pressure cycling	Elastomer cracking, flexible joint leakage, improper rotational stiffness, high bending moment, crack initiation	Fracture, rupture due to contact/wear between floater and SCR

structures allowed production in areas where rigid pipes were not an economically viable choice. Approximately 85% of risers designed for floating systems are flexible risers (Hokstad et al., 2010). Flexible pipes are crucial for subsea activities worldwide and mainly for Norwegian oil and gas production facilities, since 1986 (Leira et al., 2015). There are two types of flexible pipes available, bonded and unbonded. As the unbonded pipes are largely used by oil and gas industry, they will be the focus of this review.

There are more than 3500 dynamic unbonded flexible risers in operation worldwide. The average riser age is more than 10 years and a great number of risers are soon reaching their original design service life of 15–25 years (Muren et al., 2016).

According to Dos Santos et al. (2010), the technology qualification of flexible pipes was not capable to anticipate the variety of failure mechanisms that followed the first years in use. The author attributes two main reasons for that: the first is the high-patented environment surrounding the flexible risers technology development, where algorithms and degradation models are closed to the market, and the second is the lack of high level independent design verification. Here, high level regards the completeness of the verification, with no judgment to its quality. Fig. 4 exemplifies some of the failure modes that were described in this section, summarized in Table 3.

Due to their complex layered configuration, flexible pipes are more vulnerable to damage and present high number of failure modes. Moreover, the integrity management becomes more challenging because of each layer is made of a different material. According to 4 Subsea (2013), in a report for PSA-Norway, several flexible risers fail before reaching their intended lifetime, actually 25% of offshore flexible risers in Norway were replaced without meeting their design service life.

The need to study flexible pipes is obvious due to the knowledge and technology gaps that need to be overcome to meet integrity requirements. In order to fill these gaps, it is essential that manufacturers, operators and regulatory agencies cooperate with each other. In 2009, a Joint Industry Project (JIP) was started by Oil and Gas UK and led by SureFlex, including oil and gas operators, a flexible pipe manufacturer and a regulatory authority. The aim was to collect data about flexible pipe usage, degradation and incidents. Recently, Norwegian Petroleum Safety Authority (PSA) started to manage the Corrosion and Damage Database (CODAM) in order to report incidents and injuries of offshore structures and pipeline systems on the Norwegian Continental Shelf (NCS). Through exchanged information, standards and guidelines for safe fabrication and operation of flexible pipe systems can be improved.

Based on API RP 17B, Simonsen (2014) raised nine most probable failure modes that can occur in flexible pipes: collapse, burst, tensile rupture, compressive rupture, overbending, torsional rupture, fatigue, erosion and corrosion. These failure modes will be explained next.

#### 3.2.1. Collapse

Common failure mechanisms that could cause carcass collapse of a flexible riser are excessive force or pressure, fabrication anomalies, erosion, carcass corrosion, and installation damage (Simonsen, 2014). Focusing on flexible pipes used in production activities, the main risk they are subject is the sand content in the produced fluids. The sand can cause erosion on the innermost pipe layer (carcass) – and by this way, its collapse resistance decreases. This situation is more likely to happen in gas production pipes.

Clevelario et al. (2010) developed a numerical model to predict flexible pipe collapse resistance when subjected to curvature. The authors aim to assess and quantify the effects of curvature on the flexible pipe collapse resistance in the ultradeep water of Brazilian pre-salt. According to the authors, the flexible pipe bending configuration is amongst the factors that can affect its suitability to service in extreme water depths (~2500 m) since it creates a dissymmetry between both the compressed and extended pipe areas. The carcass and pressure armour gaps in these areas vary and reduce the overall pipe collapse resistance. However, according to Clevelario et al. (2010), some simple design solutions can be

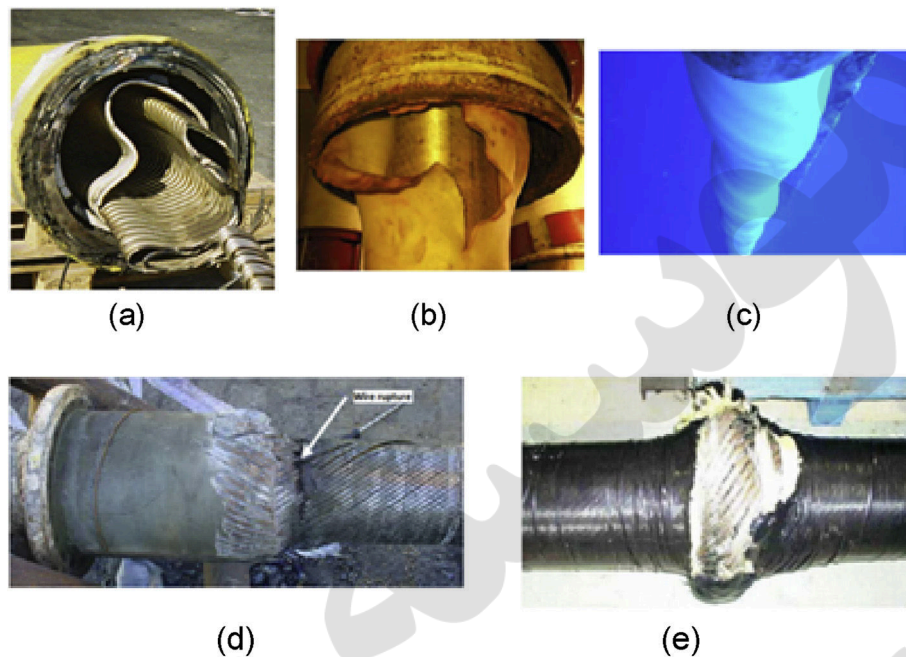

Fig. 4. Failure modes of flexible risers: (a) carcass collapse; (b) rupture of external sheath due to blocked vent tubes; (c) torsion at riser top due to ruptured armour wires; (d) tensile armor wire rupture due to fatigue; (e) birdcaging (Simonsen, 2014).

incorporated into flexible pipes to improve its overall collapse resistance and compensate for any possible reduction caused by bending. The reader is encouraged to read Cleavelario et al. (2010) for more information about these design solutions.

Based on data from CODAM, collapse is the most common incident in the NCS, being more susceptible to happen in double annulus risers. Statoil had several incidents of such risers, with carcass collapse observed in three different double annulus risers at Njord A, Visund and Snorre B fields (Simonsen, 2014).

### 3.2.2. Burst

Burst is mainly caused by rupture of tensile and/or pressure armors due to excessive internal pressure. The rupture of the external sheath can also cause loss of pipe integrity. Other defects and failures, as fabrication imperfections, internal corrosion and erosion, or external abrasion, can also lead to burst by pipe weakening (Simonsen, 2014).

Many incidents in flexible risers due to burst are described in CODAM. Simonsen (2014) emphasized two events where rupture of external sheath led to burst. The first one was a rupture in the external

Table 3  
Summary of most common failure modes (Simonsen, 2014).

Failure mode	Failure mechanisms	Occurrence
Collapse	Excessive tension External pressure Residual pressure in annulus Fabrication, transportation installation error Aging of polymer (shrinking) Ovalization	Large problem, multiple reports both in CODAM and SureFlex JIP. Problem worldwide.
Burst	Rupture of tensile armour wires Rupture of pressure armour wires Residual pressure in annulus	Burst of the outer sheath is a common problem. Rupture of tensile wires may be a problem for deepwater developments.
Tensile failure	Excessive tensile force Large dynamic movement Corrosion combined with high tensile loads	Not a frequent failure mode. High risk for corroded wires in deepwater developments.
Compressive failure	Radial buckling Upheaval buckling	Radial buckling (bird-caging) has been reported several times worldwide.
Overbending	Excessive bending force Installation error Ancillary equipment	Problem at end of pipelines and TDP for risers. Several occurrences due to sloppiness in the 90's.
Torsional failure	Large dynamic movement Large environmental forces	Not a frequent failure mode. Risers in harsh weather conditions are most vulnerable.
Fatigue failure	Rupture of tensile armour wires Rupture of tensile armour wires Rupture of pressure armour wires Aging of polymer layers Cracking of carcass or armour wires	Fatigue alone is not the most occurring failure mode due to a very high safety factor. In combination with erosion, corrosion and other factors the fatigue life is severely reduced.
Erosion	Internal erosion of carcass	No reported failures. Risk when sand bore fluids contain sand, especially in high velocity gas pipelines
Corrosion	Rupture of tensile armour wires Rupture of pressure armour wires Corrosion of internal carcass	Large problem linked to the frequent damage of outer sheath.

sheath caused by a leak, which promoted an increase in internal pressure inside the annulus and ended in burst of the external sheath. In the other case, the rupture of the external sheath occurred because the annulus vent system was not working correctly. In this case, diffused gases built up the pressure until it became larger than the burst resistance of the external sheath. This is a well-known problem and according to Simonsen (2014), past years studies were developed in order to guarantee well-functioning of the vent system and gas monitoring in flexible pipes.

### 3.2.3. Tensile rupture

Considering that tensile armor wires are already designed to support loads higher than normal service loads, tensile forces should be a problem only when they are excessive and act together with any factor that reduces the wire resistance, as corrosion or anomalies. According to CODAM and SureFlex incident reports (Simonsen, 2014), tensile rupture is not a common occurrence, just representing a low percentage of observed failures. Simonsen (2014) concluded that tensile failure is a threat to pipe integrity just when it is combined with corrosion, abrasion, or any other factor that changes the resistance of the flexible pipe.

### 3.2.4. Compressive rupture

Ribeiro et al. (2003) used a three-dimensional finite element model to predict the local mechanical behavior of flexible risers under compression. The authors concluded that the axial compression stiffness is much lower than the tension one; the tensile armors and the plastic sheaths are responsible for this behavior; the wires of the tensile armors not only move radially, but also laterally resulting in high bending stresses in these wires, and finally, that compression in flexible risers also generate gaps between layers.

A failure mechanism called radial buckling or bird-caging can happen when a flexible pipe experiences large compressive loads, causing wire disordering. This mechanism is usually avoided when the outer sheath is “intact” and buckling resistance is high. It is no longer a common phenomenon because new pipes use to have a high strength Kevlar® tape preventing bird-caging. This failure mode is more likely to happen in static flowlines. For a properly designed flexible riser, with or without an intact outer sheath, it should not be an issue (Muren, 2007). However, a later study done by SureFlex (Simonsen, 2014), stated that in 2010, 5% of flexible pipes incidents around the world were classified as bird-caging, which indicates that this failure mode should also be addressed.

### 3.2.5. Overbending

According to Simonsen (2014), the overbending failure mode in risers is more likely to happen at the touch-down point (TPD).

Overbending can affect almost all the layers of a flexible pipe. Simonsen (2014) stated that loads induced by overbending can affect the pipe in different ways: collapse due to compression forces may occur at the carcass and internal pressure sheath; rupture of internal or external pressure sheath due to tension forces induced by overbending; cracking of the outer sheath, and unlocking of carcass and pressure armor layers due to pipe strength reduction if the bending stress is excessive.

Although overbending affects many layers of a flexible pipe, only one incident concerning this failure mode was reported in the Norwegian sector. In this case, the failure happened during installation. This failure mode used to be a current UK problem in the 90's, but it is not frequent anymore (Simonsen, 2014).

### 3.2.6. Torsional rupture

As the tensile armour wires are configured in a helical pattern they are subjected to tension or compression as the riser is twisted. Excessive tension loads due to twisting may lead to rupture of one or several wires. According to Simonsen (2014), torsional force in either direction on the flexible pipe may pose problems. If the force is in the same direction as the helical pattern of the wires, they will tighten and the collapse of the carcass and/or internal pressure sheath may occur. If the torsional force acts in the other direction, the wires may be subjected to excessive

compression force causing radial buckling or unlocking of the armour wires. Thereby, torsional rupture is a flexible riser failure mode to be aware of because it can lead to other failures modes, like structure collapse. However, it is not reported as the main cause of incidents. Risers operating in hard environmental situations (wind, waves and current) are more vulnerable to torsional failure.

### 3.2.7. Fatigue

Flexible pipes experience fatigue failure due to cumulated cyclic stresses in different layers. The fatigue challenges for deepwater risers are mainly concentrated at top due to bending combined with high tension, and at seabed touch down area due to bending combined with high pressure loads. This is also driven by the fact that almost all deepwater risers are in a free standing configuration (Nielsen et al., 2008). The Norwegian offshore sector in the North Sea has done a research about fatigue failure in flexible pipes and it was observed that, in average, flexible risers were in service just 50% of its intended lifetime (Muren, 2007).

De Lemos et al. (2005) stated the most important failure modes of unbonded flexible risers associated to fatigue as:

- Fatigue associated with the wear of the tensile armors;
- Pure fatigue of the tensile armors;
- Fatigue associated with the wear of the pressure armors;
- Corrosion fatigue;
- Fatigue of the polymeric layer; and
- Fatigue in the armors at the end fittings.

In deep water environments, the fatigue failure of tension wires near the end connection is an occurrence to be aware of (Simonsen, 2014). There is a significant change in stiffness between the riser and the connector in the region close to the end fitting. This structural discontinuity strongly influences the fatigue processes in the tensile axial wires at and embedded in the connector. Progressive fatigue failure, possible accelerated by corrosion, can occur (McCarthy and Buttle, 2012).

The majority of the reported cases of damage to flexible risers describe damage located in the top section of the riser, close to the bend. These include external sheath damage, corrosion and/or fatigue induced damage to the tensile armors, and torsional instability associated to tensile armor rupture (Elman and Alvim, 2008). Damage to the outer sheath, which may lead to flooded annulus and, consequently, corrosion of the tensile and pressure armor wires, degradation of the polymer layers, increase of fatigue damage and decrease of the service life of a pipe. Experimental tests and numerical models have been done in order to allow a better prediction of fatigue life of armor wires.

Authors like Corrigan et al. (2009) and Kershaw et al. (2014), agree that the flexible riser external sheath has a higher risk of damage between the wave zone and the topsides hang-off, potentially resulting in tensile armor corrosion or corrosion-fatigue. Nielsen et al. (2008) attribute to vessel motion and wave loading as the riser fatigue drivers. Saunders and O'Sullivan (2007) pointed out that external sheath damage is the major cause of flexible risers failures, representing around 37% of the damage population in 2007, as can be seen in Fig. 5.

In their work, Nielsen et al. (2008) stated that corrosion-fatigue properties are highly reduced in connection with sour service. The armour wires can be subjected to a corrosive environment in case of partly or entirely water filled annulus, that changes significantly along its length due to the hydrostatic pressure head. Consequently, the fatigue assessment may require that different S-N curves be applied along riser sections reflecting the different partial pressures of the permeated constituents (Nielsen et al., 2008).

Clements et al. (2006) concentrates their studies on the processes of understanding the materials under corrosion fatigue conditions and the development of material design curves. According to the authors, although fatigue and corrosion fatigue testing of flexible pipe armour wires has been well documented over the years, little has been published

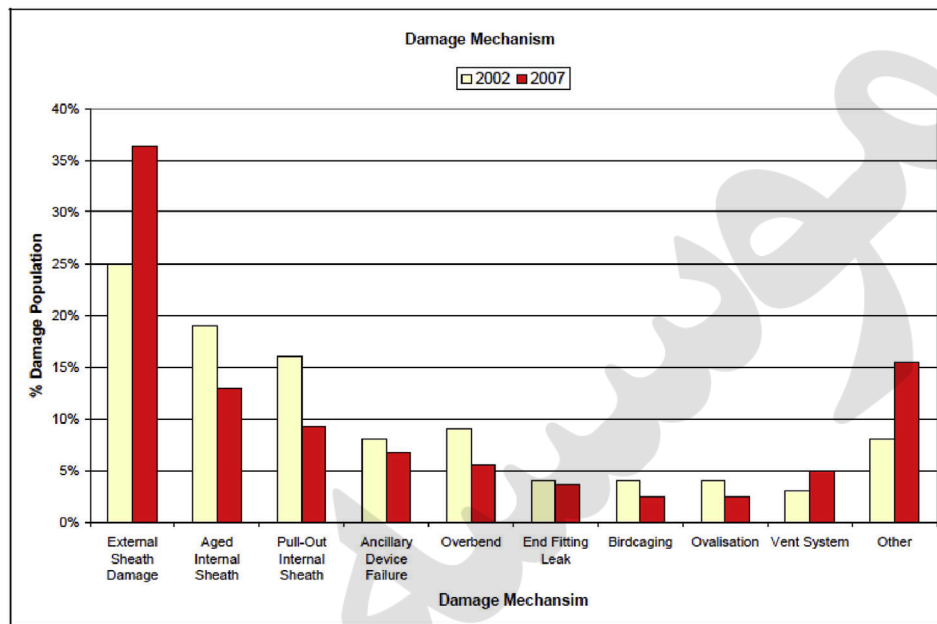

Fig. 5. Chart showing the most significant causes of flexible pipe damage in 2002 and 2007 (Saunders and O'Sullivan, 2007).

to describe the effect of different test protocols and test set-ups. The armour wire fatigue capacity based upon representative S-N curves and the Palmgren-Miner linear damage hypothesis is normally applied when accumulated fatigue damage (Nielsen et al., 2008) is calculated. Clements et al. (2006) reported the resulting S-N curves from different test protocols and how these increase or reduce conservatism in service life analysis.

According to Simonsen (2014), due to intense efforts in researches and technologies, the number of incidents due to fatigue failures in flexible pipes is decreasing. In Norway for example, there is no register of fatigue failure of tensile wires for latest years. However, when operations occur in sour environment, like Brazil and West Africa, fatigue failures in tensile armors are still occurring. Although it is a complicated failure mode, considering that it affects all different layers of a flexible pipe, its occurrence can be avoided with a high safety factor, assuming that its mechanisms are not influenced by any other factor that could decrease the fatigue strength, like corrosion.

### 3.2.8. Erosion

According to Simonsen (2014), erosion alone is not a potential cause of loss of pipe integrity. However, happening concomitantly with corrosion, thinning of the carcass may cause rupture or collapse of a pipe. In this case, erosion “destroys” the corrosion protecting layer turning the carcass more susceptible to fail. Erosion can happen due to the presence of particles in produced fluids and also by the development of hydrates. The particles collide with the internal wall of the carcass reducing the thickness of the steel layer. The erosion is more likely to happen in gas production pipes, where the solid fragments flow with higher velocity. It is noticed that there is no report exposing failures in flexible pipes exclusively caused by erosion.

According to Helgaker et al. (2017), erosion in smooth pipes can be determined with industry-standard erosion-prediction methodologies. However, these models are usually valid for smooth pipes only, with limited information available on erosion in flexible pipes. The work of Parsi et al. (2014) describes key factors influencing erosion and reviews available erosion equations. The authors discuss solid-particle erosion modelling for oil and gas wells and pipelines. These models are used to limit the maximum production flow rates and avoid excessive erosion damage.

Oka et al. (2005) and Oka and Yoshida (2005) developed an equation

for estimating erosion damage caused by solid particle impact. Arabnejad et al. (2015) proposed a semi-mechanistic model for the erosion of different target materials due to solid particles. These models can be used to predict erosion wear caused by sand production in oil-and-gas components.

### 3.2.9. Corrosion

In the same work of Simonsen (2014), the author stated that corrosion alone is not a typical cause of failure in flexible pipes. However, when in combination with high static or fatigue loads, it can cause loss of pipe integrity. The contact of the seawater saturated with oxygen with the steel layers induces oxidation and it is a common reason for corrosion. The author concluded that corrosion happens mostly when seawater and oxygen can flow into the annulus due to a breach in the outer sheath. Breach normally occurs during transportation and installation of a flexible pipe, when damage used to be neglected. This problem is highly appearing in statistics and needs to be studied.

### 3.2.10. Other failure modes

Besides the nine failure modes previously described (based on the API RP 17B), seven other different failure modes were studied by SeaFlex and were reported by Muren (2007). These failure modes include: hydrogen embrittlement, impacts, pigging accidents, ageing, wear, vibrations in gas pipes and annulus threat environment. However, facing that flexible pipe is a current and common topic of many early and recent studies, these additional failure modes will not be deeply covered in this report. For more data about failure in flexible pipes, some studies can be suggested. Hokstad et al. (2010) performed a wide study about subsea equipment with focus on common failures experienced by each layer of a flexible pipe. Braga et al. (2011) addressed the use of continuous vibration measurements to detect rupture of wires in the tensile armor layers of flexible risers. Leira et al. (2015), proposed integrity assessment and qualification of lifetime extension based on a specific case study, and also repair solutions for outer sheath damage, facing the fact that it is one of the most common failures in flexible pipes. Shen and Jukes (2015) discussed key factors impacting on the stress and fatigue damage of unbonded flexible risers and the potential failure modes at a HPHT deepwater environment. Subsea (2013) reported a study about unbonded flexible pipes where some incidents observed by PSA from CODAM database were analyzed considering their causes, possible



solutions and mitigation actions.

Some works about vibration in gas pipes can be also emphasized. Swindell and Belfroid (2007) addressed the technical issues associated with high amplitude pressure pulsations generated by gas flow through flexible risers. Zheng et al. (2012) showed that the influence of chaotic response on the resulting fatigue damage can be as significant as that of higher harmonic components. Finally, Belfroid et al. (2009) studied the flow induced pressure pulsations (FIP) from shackle-type carcass. According to them, when gas passes through the flexible riser, vortex shedding occurs at each of the internal corrugations, generating pressure pulsations, which induce vibration forces and excite mechanical natural frequencies, leading to pipe fatigue.

#### 4. Umbilical cable failures

In general, subsea umbilicals consist of an arrangement of high collapse resistance (HCR) hoses to chemical injection, thermoplastic hoses to hydraulic control of valves, electrical cables (signal, control or power supply), tensile armors and a polymer layers. When a subsea component fail, operators have two options: to perform an underwater repair or bring equipment up to the surface to repair it. In the case of umbilical cables, depending on the damage extension, it is often necessary to stop production, remove the whole umbilical, and replace it, resulting in high costs to the company. The failure in umbilical cables can occur during manufacture, installation and service. Bryant (1990) describes the most common failure mechanisms for such equipment. The author divides umbilical cable failures according to their driving mechanisms: tension or compression, torsion, fatigue, wear and sheaving. In general, tension and compression loads are within the umbilical working limits of and are predominantly supported by armor and other system reinforcements. The failures caused by tension or compression can be avoided by preventing the umbilical minimum bend radius and remaining it within the manufacturers recommendations for tensile loading, both when the umbilical is straight and bent.

As a rule, umbilical cables have low torsional stiffness and therefore are susceptible to damage resulting from excessive application of torsional loads. According to Bryant (1990), the risk of torsion damage is higher during umbilical installation. Such damage may occur at the point immediately below the final sheave on a laying vessel as the vessel makes a turn. The mechanism involves the contribution of umbilical weight forcing the twist, induced by the vessel maneuver, in relation to the point where friction prevents umbilical rotation, i.e., as it leaves the sheave. The result of torsion damage will be either 'bird-caging' or 'necking' of amour wires and/or helical components. Many of the problems associated with laying umbilicals are related to torsion effects as looping. These effects can be minimized by always keeping umbilicals under tension and with the aid of torque balanced armor (Bryant, 1990).

Another very common damage in umbilicals is fretting damage because of continuous bending and load cycling. To avoid such damage, it is recommended the use of high abrasion resistance jackets to cover the most sensitive materials, such as Kevlar®. In addition, to ensure that its internal components are maintained in relative position to each other, it

is necessary to provide fillers, which ensure the most symmetrical configuration as possible. According to Bryant (1990), the braid of a hydraulic hose is sensitive to fretting damage since it is semi-mobile. The hose manufacturer must ensure that the amount of yarn on the braid layer is sufficient to withstand the loads generated by internal pressure and, at the same time, such amount of yarns does not result in tightly packed yarn, which is susceptible to fretting damage.

Fig. 6 illustrates the cross-section of a braid, showing the difference between a low packing and a high packing braid. The braid presented a less acute angle to the liner in case 2 than in case 1, and besides lowering its efficiency and capacity of load resistance, it can also induce compressive failure in the braid fibers.

Sheaving damage can be described as damage resulting from pulling of an umbilical around a sheave (Bryant, 1990), generating a very rapid change of curvature close to the sheave. If an umbilical is bent with constant curvature along the length, the core will be somewhere on the convex (tensile) side and somewhere on the concave (compression) side of the umbilical. The core components will of course tend to move from the compression to the tensile part of the core. If the umbilical is also axially loaded, there will be a pressure and a friction force between the different components (Waloen et al., 1993).

Benjaminsen et al. (1992) tried to determine the stresses and fatigue life of an axially loaded electrical umbilical running back and forth over a sheave. The authors did cyclic bending fatigue tests to investigate the influence of factors affecting fatigue life (lubrication, sheave diameter, axial load, conductor type etc); bend stiffness tests to measure the force required to bend umbilical samples over a range of sheaves, in order to evaluate its bend stiffness; core movement tests to study relative sliding of core components during bending over a sheave; and deflection tests, to study the effect of differential contraction and elongation of internal elements as the umbilical goes on and off a sheave. Those experimental tests were important to gather physical data for the development of an analytical procedure to calculate internal stresses in an umbilical being bent over a sheave, which was reported in Benjaminsen et al. (1992).

Ricketts and Kipling (1995) focused their studies in fatigue tests of an electrohydraulic umbilical passing through a sheave aiming to establish the effect of axial load, hose pressure, sheave diameter and wrap angle on the measured life. Among the results obtained, the effects of sheave diameter and wrap angle can be highlighted. Even though the electrical unit was central, and hence close to the neutral axis, for a bending diameter reduction of 33%, the measured reduction in the electrical conductor fatigue life was 96%. The effect of wrap angle was also marked, with a reduction from 180 to 90° leading to a life increase superior to 100%.

According to Bryant (1990), the majority of umbilical damage is associated with the use of static sheaves such as curved plates. High sheaving loads can result in removal of protective jackets and, consequently, in corrosion problems. In addition, sheaving under high loads can also result in high stress concentration in internal components of the umbilical, leading to failure. A particular interesting failure mechanism can be observed in hydraulic hoses, related to sheaving under tensile loads.



Fig. 6. Comparison between low and high packing in aramid braid (Bryant, 1990).

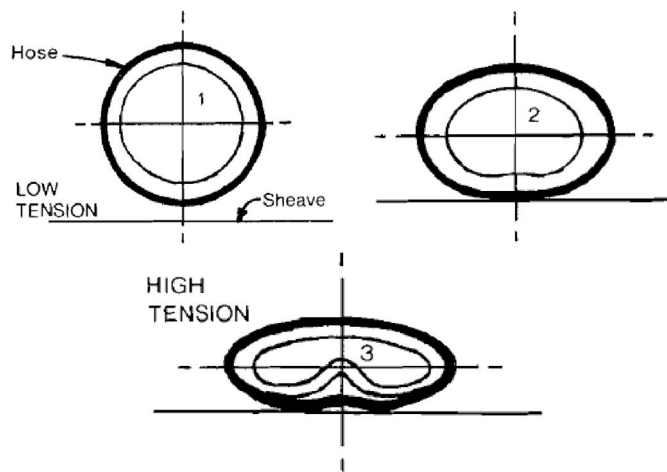

Fig. 7. Hydraulic hose failure by sheaving (Bryant, 1990).

As represented in Fig. 7, the stages of sheaving failure in hydraulic hoses comprise a transition between a perfect circular hose (1), an oval hose (2), and a point (3) at which the lower surface turns in on itself. At this point, the inwardly pointing material will be 'chased' along the axis of the umbilical as it is pulled along over the sheave. In some cases, this type of damage is recoverable by re-inflating the hose, but the material life will certainly be reduced. In other cases, the heart-shaped geometry is so pronounced that it resists inflation and subsequent bursts will occur due to the separation of the braid from the liner.

Rabelo (2013) suggested that to avoid damage in hydraulic hoses, it is necessary to keep the hoses pressurized by hydraulic fluid when the umbilical passes through pulleys and tensioners during installation. Umbilical cables are installed by launching vessels (pipe laying support vessels, PLSVs). Fig. 8 illustrates a PLSV used for the installation of umbilical cables. These vessels receive reeled umbilical cables and release them through tensioners. The minimum radial compression on the tensioners is that required to maintain the set suspended when it is released. This minimum grip should be ensured by the tensioner throughout the operation of release, and for that, a nominal value is set (required crushing load). The maximum value (maximum crushing load) is twice the difference between the nominal radial compression and minimum radial compression. According to Batrony et al. (2012), it is important that these crush load limits are defined realistically and derived using verifiably accurate methods. This requires fundamental understanding of the internal components failure modes subject to crush loading and analysis tools, which are calibrated against actual test data. Batrony et al. (2012) presented a preliminary study comparing experimental results with FEA simulations on a sample steel tube umbilical under crush loading.

The minimum radial compression required in tensioners is function of



Fig. 8. Pipe laying support vessel (PLSV) and its tensioner (Rabelo, 2013).

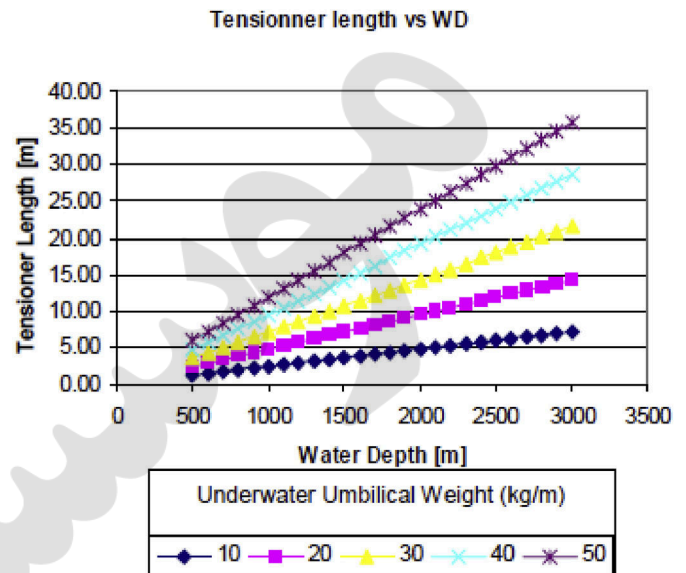

Fig. 9. Tensioner Length versus water depth and umbilical weight (Dieumegard and Fellows, 2003).

the load being transferred, the lower dynamic friction coefficient between the external coating and tensioner shoe structure, the length of the tensioner and the number of tensioners which will be effectively employed. The maximum radial compression specified (design crushing load) is dependent on the active traction, because this could end up stretching the wires of the armour and inducing the effect of crushing (squeeze) in the inner layers. Dieumegard and Fellows (2003) describe the design and installation of a deepwater metallic tube umbilical and give reference to the total length of tensioner required to install it under several water depths and umbilical weights. As shown on Fig. 9, the total length of tensioner required to install an umbilical in ultra deepwater can be significant.

Umbilical sections are submitted to radial compression when passing through tensioners and launching wheel and these loadings can cause significant bending in the internal components of the umbilical. In addition, the tensile armor submits the functional elements to mechanical pressure, inducing ovalizations in the umbilical hoses. Rabelo (2013) concludes that it is essential to launch the umbilical cable with the hydraulic hoses completely full of hydraulic fluid to avoid hose failure.

Rabelo (2013) describes a study of Petrobras about the main causes of failures in umbilicals installed in production wells. This study compiled installation and inspection reports of the company, publications of other operators, and consultation to umbilicals manufacturers in order to catalog the major non-compliances that occurred in this equipment. Major cataloged failures include:

- Cracks in the outer jacket:** nucleation and propagation of cracks in high density polyethylene (HDPE);
- Ripples:** loss of functionality of internal components due to non-uniform stress distribution during the passage through PLSV tensioners;
- Kinks:** umbilical twist generating balancing loss;
- Offset of the external sheath in HDPE:** offset of the outer jacket allowing exposure of the tensile armour;
- Tensile armour wire break:** break of the wire in the welding region.

These failures illustrated in Fig. 10 occurred because of manufacturing defects, handling or design fitness to supplier manufacturing facilities. According to Rabelo (2013), the problems

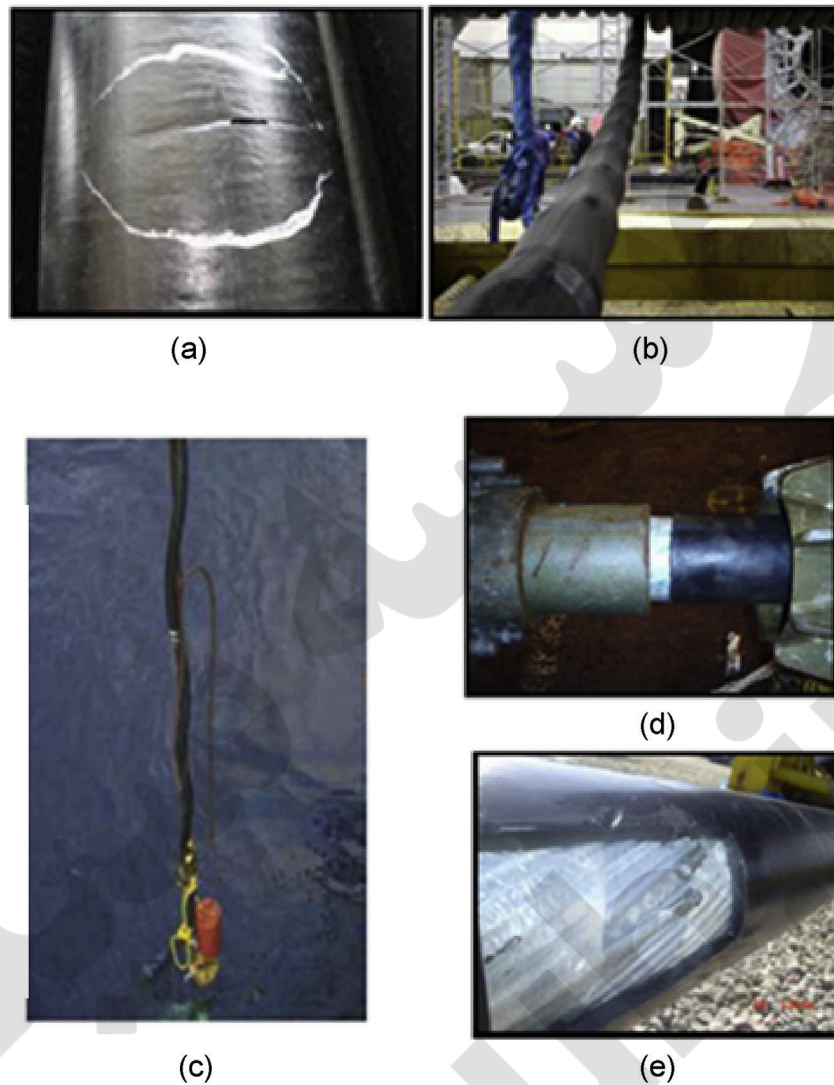

Fig. 10. Umbilical failures: (a) cracks in the outer jacket; (b) ripples; (c) kinks; (d) offset of the external sheath in HDPE, and (e) tensile armour wire break (Rabelo, 2013).

caused by handling, installation and operation are closely linked to hydraulic hoses failures. These hoses have low resistance to collapse, and this failure mode appears as the main cause of umbilical failures experienced. The collapse is manifested by gradual increase of ovalization in hose section. After some loading cycles, such crease leads the hose to burst. Fig. 11 illustrates the failure of a hydraulic hose.

Due to the hydraulic hoses limitation to external pressure (from 150

to 200 psi), it was established as prerequisite and design premise that the umbilical installation in any depth must be made under internally pressurized hoses and no air inside. The presence of air (or other compressible fluid) allows the development of creases and deformation (ovality) that result in hose failure.

Rabelo (2013) reported a true case of umbilical cable hydraulic hose failure. It corresponds to a GTX-443 injection well, in water depths of

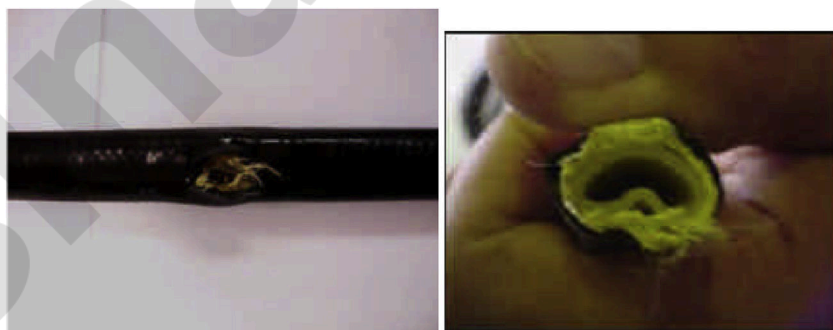

Fig. 11. Hydraulic hose failed in operation (Rabelo, 2013).

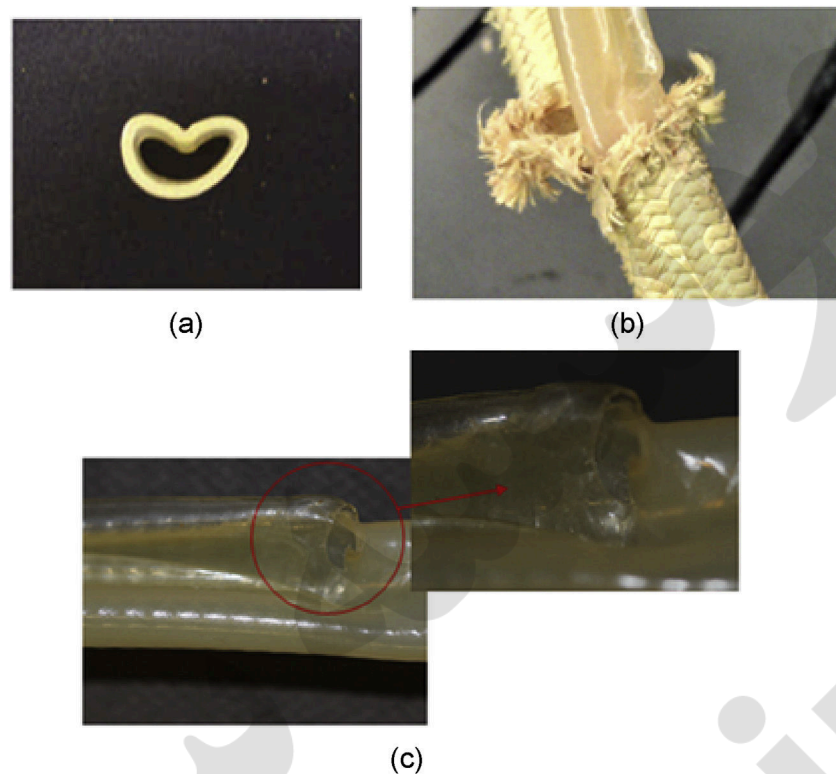

Fig. 12. Burst failure aspect: (a) hose cross-section showing a crease; (b) aramid layer rupture; and (c) liner burst in the crease region (Rabelo, 2013).

1181 m, connecting the platform P-93 by a five functions electro-hydraulic umbilical, containing five hydraulic hoses of 3/8". The leakage of the hydraulic fluid driven in four of the five hoses was identified after valve control loss. One of these hoses was dissected and the combination of external and internal pressure was identified as the most probable failure reason. According to Rabelo (2013), the main findings about the hoses failure were: rupture of the polyurethane outer jacket; burst aspect in the aramid layer; extensive crease along sample length; Nylon 11 liner showing yellow coloration. Fig. 12 shows a dissected hose and illustrates the failure aspect by burst.

Almeida et al. (2013) also conducted a study on hydraulic hoses failure due to pressure loads. The authors proposed a new arrange to umbilical internal components aiming to reduce the applied tensile load on hoses. To this end, numerical FE analyses as well experimental tests were conducted. According to this study, due to the helical configuration of the tensile armour, part of the applied load is transferred as pressure on the intermediate layers, which can lead to the crushing of the internal components of the umbilical (electrical cables, hydraulic hoses etc.).

From the numerical results, the authors realized that the hoses were the components with higher tension levels during dynamic tests. They suggested modifications of the umbilical cross-section to reduce tensile levels, by changing the mobility of internal components (hydraulic hoses and electrical cables). The simulation of the new cross-section arrange demonstrated that it behaves inversely to the older one, in which the electrical cables were free to move before they come in contact with the inner sheath. With the new cross-section arrange, the hoses were made free to move, which caused a reduction of about 53% in the maximum stress. Additionally, the stresses became better distributed and symmetric, in contrast to the older arrange, where some regions of stress concentration were observed.

Recently, Drumond et al. (2016) studied the failure of umbilicals hydraulic hoses due to pressure loads and proposed an alternative material for the manufacture of the hose inner layer. The authors based their work on the comparison between the material currently used (Polyamide

11) and a fluorinated elastomer, Viton<sup>®</sup>. To compare the mechanical behavior of both materials, uniaxial tensile tests as well as nonlinear FE simulations were performed. The numerical results obtained showed that both Polyamide 11 and Viton<sup>®</sup> did not fail under external pressure. However, Polyamide 11 concentrates high plastic deformations after collapse, which can lead to localized hose rupture under internal pressure. For Viton<sup>®</sup>, it was found that the material concentrates deformations during collapse but they are recovered when internal pressure is applied. To propose the replacement of Polyamide 11 by Viton<sup>®</sup>, it was showed that the latter has chemical compatible with the hydraulic fluid. Then, ageing tests under temperature were conducted to check if the polymer loose mass, swell and preserve its mechanical properties (Drumond et al., 2016) after ageing. It was found that the changes in mechanical properties were not severe, as well as the swelling and mass loss effects.

A previous work (Legallais et al., 1993) reported another failure mode on umbilicals hydraulic hoses: the ability of some fluids and gases to permeate the hose layers. Despite of being small, permeation rate at large distances leads to loss of significant fluid volume. Legallais et al. (1993) based their research on a fluid commonly injected in wells, the methanol. A new material based on cross-linked polyethylene was developed in order to replace Polyamide 11 or thermoplastic polyester inner layer of hydraulic hoses. For these materials, methanol permeation rates vary with temperature from 150 to 5 g/m<sup>2</sup> (mm.dia) for Polyester, and from 190 to 13 g m<sup>2</sup>/(mm.dia) for Polyamide 11. Legallais et al. (1993) have developed a specific degree of cross-linked high density polyethylene, named Ducoflex<sup>®</sup>. Such material is applicable to methanol injection (or other fluids) and can replace Polyamide 11 or thermoplastic polyester at temperatures up to 90 °C.

## 5. Conclusions

This paper aims at reporting a literature review on failure events experienced by the oil and gas industry concerning pipelines, risers, and

umbilical cables.

Pipelines are structures widely used in oil and gas production facilities and occasionally may fail leading to hydrocarbons releases. In the past ten years, three hundred offshore pipeline incidents happened, and seventy one of them involved hydrocarbon releases (Aljaroudi et al., 2015). These numbers are relevant and pointed out the need of deeper studies about the causes of these structural failures. The main failure modes experienced by pipelines during production are identified as mechanical damage (impact or accidental damage), external and/or internal corrosion, construction defect, material or mechanical failure, natural hazards and fatigue. Taking into account the failure events reported, impact is indicated as the most frequent cause of failure modes, representing 56% of the incidents in the North Sea. Another relevant failure mode is associated with internal corrosion, which represents 31% of the incidents in the US. Internal corrosion is mostly explained by microbiologically induced corrosion (MIC) or by ingress of CO<sub>2</sub> traces combined with H<sub>2</sub>S. Facing these statistics, further studies and analysis addressing impact and corrosion failures in pipelines are strongly recommended for future studies.

Additionally, pipe buckling and overbending can result from longitudinal compressive stresses caused by an increase of temperature combined with the presence of soil friction or constrained ends (Simonsen, 2014). Concerning the pipeline-seabed interaction under waves and/or currents, a vast review of published researches is presented by Fredsøe (2016), including three issues: scour, liquefaction, and lateral stability of pipelines. The process of scour around a pipeline is dependent on the pipeline-seabed interaction, which is influenced by the movement of the pipeline due to bending along the scour process. When the pipe is located in a free span, it may vibrate as a result of waves and/or current (Sumer et al., 1989; Shen et al., 2000; Zhao and Cheng, 2010), which causes an additional pulsating flow around the pipe, leading to an expansion of the scoured-bed profile. Noncohesive soil in the seabed exposed to waves may undergo liquefaction, when pipelines placed on the seabed may sink if their submerged density is higher than the liquefied soil density. Similarly, buried pipelines may float to the bed surface when their submerged density is lower than that of the surrounding liquefied soil (Fredsøe, 2016). In terms of flow-pipe-soil interaction mechanism, advances were shown by Gao et al. (2002, 2007), and Teh et al. (2003). Gao et al. (2002) identified three characteristic stages in the process of pipe lateral instability: (a) onset of sand scour; (b) pipe rocking, and (c) pipe breakout.

Rigid risers can be split into top tensioned risers (TTR) and steel catenary risers (SCR). The main failure incidents to the former occur in workover/drilling operations. The main failure modes associated are drilling induced vibration fatigue and riser wear due to contact with the drill string. Even though steel catenary risers are not widely used, they are a very attractive option for deeper waters. However, they are very sensitive to cyclic loadings and, consequently, susceptible to fatigue failure. There are two critical fatigue areas in these structures: the vessel hang-off point and the touchdown point, where the bending moment is the highest. It can be noticed from literature review, that few studies about failure in rigid risers were accomplished.

According to Hokstad et al. (2010), approximately 85% of floating systems risers are of flexible pipe type. This is a huge number, which deserves high attention to possible failures modes, considering their wide application by industry. After a comprehensive literature review, some failure modes were identified: collapse, burst, tensile rupture, compressive rupture, overbending, torsional rupture, fatigue, erosion and corrosion. Although flexible risers may fail in different ways, collapse due to external pressure was reported as the most frequent failure mode. Failure cases involving tensile armors rupture and burst were also reported.

The paper also discussed failures in umbilical cables. Bryant (1990) reported failures due to tension or compression, torsion, fatigue, wear and sheaving. The last one is a frequent failure mechanism associated with the use of static sheaves, such as curved plates during umbilical installation. Another author (Rabelo, 2013) cataloged the major non-compliances that

occurred in umbilical cables, such as cracks in the outer jacket, ripples, kinks, offset of the external sheath, and tensile armour wire break. These failure modes are widely covered by the industry, with a lot of studies and projects aiming to mitigate or solve the related problems.

Although the readers may be concerned about the failure mechanisms of the reported structures, it is not possible to explore them in a single article. Here the aim is to bring a general view of the documented failures, so that the reader can go in deep from the mentioned references. From the analyzed structures, some key factors should be highlighted in view of the reported failures, i.e. water depth, structure complexity and environmental conditions.

The increasing water depth potentially makes the installation and operation of such structures more dangerous, since the involved loads are higher, i.e. axial tension, external pressure, bending and torsion. Most of the reported failures are directly related to conditions of extreme loads or combinations of them.

Structural complexity also increases the mechanical response modes and so far, the failure possibilities. It is clear that the multi-layered pipes and cables present much more failure mechanisms than single wall structures. Certainly, there are hundreds of publications addressing these different failure mechanisms and the readers are encouraged to access them.

Finally, the environmental conditions are always harmful for such engineering structures. They can be corrosive (chemically aggressive), dynamical (causing fatigue) and sometimes extreme within severe weather conditions. Because of this, the design, installation and operation of pipelines, risers and umbilicals will be always a challenging task.

## Acknowledgments

The authors would like to acknowledge the financial support from QPI Brasil Petróleo Ltda (ANP R&D Program) during research activities carried out at the Subsea Technology Laboratory – COPPE, Federal University of Rio de Janeiro, under the research project “Safety of Subsea E&P Operations” (PEN0-19367).

## References

- 4 Subsea, 2013. Un-bonded Flexible Risers – Recent Field Experience and Actions for Increased Robustness. Tech. rep., PSA Norway.
- Aljaroudi, A., Khan, F., Akinturk, A., Haddara, M., Thodi, P., 2015. Risk assessment of offshore crude oil pipeline failure. *J. Loss Prev. Process Ind.* 37, 101–109.
- Almeida, R.S., Mascarenhas, W.N., Andrade, J.F.A.D., Andrade, A.F.A.D., 2013, October. Application of numerical analysis tools on the performance improvement of umbilicals and their elements. In: OTC Brasil. Offshore Technology Conference.
- Amend, B., 2010, January. Early generation pipeline girth welding practices and their implications for integrity management of North American pipelines. In: 2010 8th International Pipeline Conference. American Society of Mechanical Engineers, pp. 449–458.
- Anunobi, K.U., 2012, January. External localized corrosion of topside riser system. In: SPE International Conference & Workshop on Oilfield Corrosion. Society of Petroleum Engineers.
- Arabnejad, H., Mansouri, A., Shirazi, S.A., McLaury, B.S., 2015. Development of mechanistic erosion equation for solid particles. *Wear* 332, 1044–1050.
- PHMSA, 2014. U.S. Department of Transportation, Pipeline & Hazardous Materials Safety Administration. <http://primis.phmsa.dot.gov/comm/Index.htm>.
- Batrony, M., Doak, R., Bordner, A., 2012, April. Advances on the analysis of critical failure modes of subsea umbilicals-excessive crush loading. In: Offshore Technology Conference. Offshore Technology Conference.
- Belfroid, S.P.C., Swindell, R.J., Kitney, N., 2009. Flow induced pulsations due to flexible risers. In: 2009 Offshore Technology Conference, 4–7 May 2009, Houston, Texas, USA.
- Benjaminsen, J., Brown, N., Stafford, M., Due-Andresen, S., Waloen, A.O., 1992, January. Fatigue, internal stresses and deformation of electrical umbilicals: experimental work. In: The Second International Offshore and Polar Engineering Conference. International Society of Offshore and Polar Engineers.
- Braga, A., Morikawa, S., Camerini, C.S., Camerini, M.G., Ribeiro, A.S., Simoes, T.B., 2011, January. Vibration monitoring technique to detect failure in armour wires of flexible risers. In: OTC Brasil. Offshore Technology Conference.
- Bryant, M.J., 1990. Umbilical failure-Mkchahishs amd avoidance. *Subsea Control Data Acquis. Technol. Exp.* 22, 177.
- Chiew, Y.M., 1990. Mechanics of local around submarine pipeline. *J. Hydraul. Eng.* 4 (515), 515–529. [https://doi.org/10.1061/\(ASCE\)0733-429\(1990\)116](https://doi.org/10.1061/(ASCE)0733-429(1990)116).

- Clements, R.A., Jamal, N., Sheldrake, T., 2006, January. Riser strategies: fatigue testing and analysis methodologies for flexible risers. In: Offshore Technology Conference. Offshore Technology Conference.
- Clevelario, J., Pires, F., Falcao, G., Tan, Z., Lu, J., Sheldrake, T., 2010. Flexible pipe curved collapse behaviour assessment for ultra deepwater developments for the Brazilian pre-salt area. In: Offshore Technology Conference.
- Cook, H.H., Dopjera, D.E., Thethi, R., Williams, L., 2006, January. Riser integrity management for deepwater developments. In: Offshore Technology Conference. Offshore Technology Conference.
- Corrigan, H., Ramos, R.T., Smith, R., Kimminau, S.J., El Hares, L., 2009, January. New monitoring technology for detection of flexible armour wire failure. In: . In Offshore Technology Conference. Offshore Technology Conference.
- Cosham, A., Hopkins, P., 2002, January. The pipeline defect assessment manual. In: 2002 4th International Pipeline Conference. American Society of Mechanical Engineers, pp. 1565–1581.
- De Lemos, D., Alberto, C., Vaz, M.A., 2005, January. Flexible riser fatigue design and testing. In: The Fifteenth International Offshore and Polar Engineering Conference. International Society of Offshore and Polar Engineers.
- De Stefanis, V., Carr, P., 2010, January. A model to estimate the failure rates of offshore pipelines. In: 2010 8th International Pipeline Conference. American Society of Mechanical Engineers, pp. 437–447.
- Dieumegard, C., Fellows, P., 2003, January. Installation of metallic tube umbilicals in 3,000 meters water. In: Offshore Technology Conference. Offshore Technology Conference.
- DNV, 2008. Riser Integrity Management. Tech. rep., DNV-RP-F206.
- DNV, 2009. Integrity Management of Submarine Pipeline Systems. Tech. rep., DNV-RP-F116.
- Draper, S., An, H., Cheng, L., White, D.J., Griffiths, T., 2015. Stability of subsea pipelines during large storms. *Phil. Trans. R. Soc. A* 373 (2033), 20140106.
- Drumond, G.P., Pasqualino, I.P., Costa, M.F., 2016. Study of an alternative material to manufacture layeredhydraulic hoses. *Polym. Tetsing J.* 53, 29–39.
- Elman, P., Alvim, R., 2008, January. Development of a failure detection system for flexible risers. In: The Eighteenth International Offshore and Polar Engineering Conference. International Society of Offshore and Polar Engineers.
- Fredsoe, J., 2016. Pipeline–seabed interaction. *J. Waterway, Port, Coastal, Ocean. Eng.* 142 (6), 1–20.
- Gao, F.P., Gu, X.Y., Jeng, D.S., Teo, H.T., 2002. An experimental study for wave-induced instability of pipelines: the breakout of pipelines. *Appl. Ocean Res.* 24 (2), 83–90.
- Gao, F.P., Yan, S., Yang, B., Wu, Y., 2007. Ocean currents-induced pipeline lateral stability on sandy seabed. *J. Eng. Mech.* 133 (10), 1086–1092.
- Helgaker, J.F., IJzermans, S., Landheim, T.J., Eeg, T.B., Hverven, S.M., Piotrowski, P., 2017. Large-scale erosion testing of an unbonded flexible pipe. *SPE J.* 22 (03), 736–745.
- Hokstad, P., Habrekke, S., Johnsen, R., Sangesland, S., 2010. Ageing and Life Extension for Offshore Facilities in General and for Specific Systems. Tech. rep., SINTEF.
- Jeng, D.S., 2013. Porous Models for Wave-seabed Interactions. Springer, Berlin.
- Kershaw, K., Binny, W., McCarthy, J., Buttle, D., Eckold, G., 2014, May. Offshore application of a novel approach to the inspection of flexible risers. In: Offshore Technology Conference. Offshore Technology Conference.
- Kimiaei, M., Randolph, M., Ting, I., 2010, January. A parametric study on effects of environmental loadings on fatigue life of steel catenary risers (using a nonlinear cyclic riser-soil interaction model). In: ASME 2010 29th International Conference on Ocean, Offshore and Arctic Engineering. American Society of Mechanical Engineers, pp. 1085–1093.
- Leckie, S.H.F., Draper, S., White, D.J., Cheng, L., Fogliani, A., 2015. Lifelong embedment and spanning of a pipeline on a mobile seabed. *Coast. Eng.* 95, 130–146.
- Legallais, L., Stratfold, M., Hardy, J., 1993, January. A new generation of umbilical hoses. In: Offshore Technology Conference. Offshore Technology Conference.
- Leira, B., Berge, S., Løtveit, S.A., Fergestad, D., Langhelle, N., 2015, May. Lifetime extension of flexible risers: a generic case study. In: Offshore Technology Conference. Offshore Technology Conference.
- McCarthy, J.C., Buttle, D.J., 2012, January. Maps-fr structural integrity monitoring for flexible risers. In: The Twenty-second International Offshore and Polar Engineering Conference. International Society of Offshore and Polar Engineers.
- MCS, 2009. Hybrid Well Riser Risk of Failure and Prevention. Tech. rep., MMS TAR&P.
- Muren, J., 2007. Failure Modes, Inspection, Testing and Monitoring. Tech. rep., Seaflex.
- Muren, J., Eide, J., Engelbreth, K.I., Christensen, H., Nilsen-Aas, C., 2016, May. Lifetime extension of flexible risers based on field experiences. In: Offshore Technology Conference. Offshore Technology Conference.
- Nazir, M., Khan, F., Amyotte, P., 2008. Fatigue reliability analysis of deep water rigid marine risers associated with Morison-type wave loading. *Stoch. Environ. Res. Risk Assess.* 22 (3), 379–390.
- Nielsen, N.J.R., Weppenaar, N., de la Cour, D., Kristensen, C., 2008, January. Managing fatigue in deepwater flexible risers. In: Offshore Technology Conference. Offshore Technology Conference.
- Oka, Y.I., Yoshida, T., 2005. Practical estimation of erosion damage caused by solid particle impact: Part 2: mechanical properties of materials directly associated with erosion damage. *Wear* 259 (1), 102–109.
- Oka, Y.I., Okamura, K., Yoshida, T., 2005. Practical estimation of erosion damage caused by solid particle impact: Part 1: effects of impact parameters on a predictive equation. *Wear* 259 (1), 95–101.
- Buberg, T., 2014. Design and Analysis of Steel Catenary Riser Systems for Deep Waters. PARLOC, 2003. The Update of Loss of Containment Data for Offshore Pipelines. Tech. rep. Mott MacDonald Ltd.
- Parsi, M., Najmi, K., Najafifard, F., Hassani, S., McLaury, B.S., Shirazi, S.A., 2014. A comprehensive review of solid particle erosion modeling for oil and gas wells and pipelines applications. *J. Nat. Gas Sci. Eng.* 21, 850–873.
- Quintin, H., Legras, J.L., Huang, K., Wu, M., 2007, January. Steel catenary riser challenges and solutions for deepwater applications. In: Offshore Technology Conference. Offshore Technology Conference.
- Rabelo, A.S., 2013. Estudo do Comportamento de MangueirasTermoplásticas de UmbilicaisSubmarinosSubmetidas a CarregamentosMecânicos (Dissertação de M.Sc, COPPE/UFRJ, Rio de Janeiro, RJ, Brasil).
- Ribeiro, E.J., de Sousa, J.R., Ellwanger, G., Lima, E., 2003, January. On the tension-compression behaviour of flexible risers. In: The Thirteenth International Offshore and Polar Engineering Conference. International Society of Offshore and Polar Engineers.
- Ricketts, D.C., Kipling, B., 1995, January. Bend-over-sheave fatigue testing of an electrohydraulic umbilical. In: Umbilicals the Future: Proceedings of an International Conference. Society of Underwater Technology.
- Roche, M.G., 2004, January. An experience in offshore pipeline coatings. In: CORROSION 2004. NACE International.
- Roche, M., 2007, January. Corrosion management: a key issue in pipeline integrity. In: International Petroleum Technology Conference. International Petroleum Technology Conference.
- Rose, D.J., 1999, January. Pipeline failure offshore California: effective oil spill response in an environmentally sensitive and politically Charged area. In: SPE/EPA Exploration and Production Environmental Conference. Society of Petroleum Engineers.
- Samant, A., Singh, S., 1998. Role of Microbial Induced Corrosion in Subsea Water Pipeline Failure. Tech. rep., NACE International, Houston, TX (United States).
- Dos Santos, R.L., Matos, B.R., Raposo, C.V., Kumar, R., 2010, January. Flexible pipe integrity analysis using event trees. In: Offshore Technology Conference. Offshore Technology Conference.
- Saunders, C., O'Sullivan, T., 2007, January. Integrity management and life extension of flexible pipe. In: Offshore Europe. Society of Petroleum Engineers.
- Sen, T.K., 2006. Probability of fatigue failure in steel catenary risers in deep water. *J. Eng. Mech.* 132 (9), 1001–1006.
- Sen, T.K., 2008, January. Fatigue in deepwater steel catenary risers: a probabilistic approach for assessment of risk. In: Offshore Technology Conference. Offshore Technology Conference.
- Shen, Y., Jukes, P., 2015, July. Technical challenges of unbonded flexible risers in HPHT and deepwater operations. In: The Twenty-fifth International Offshore and Polar Engineering Conference. International Society of Offshore and Polar Engineers.
- Shen, Z.H., Liu, Y.B., Li, Q.P., Huang, Q.H., Zhu, F.R., 2000. Experiments on interaction between current-induced vibration and scour of submarine pipelines on sandy bottom. *China Ocean. Eng.* 14, 423–434.
- Simonsen, A., 2014. Inspection and Monitoring Techniques for Un-bonded Flexible Risers and Pipelines. Master Thesis. University of Stavanger, Norway.
- Stadie-Frohbs, G., Lampe, J., 2013, June. Risk based inspection for aged offshore pipelines. In: ASME 2013 32nd International Conference on Ocean, Offshore and Arctic Engineering. American Society of Mechanical Engineers.
- Sumer, B.M., 2014. Liquefaction Around Marine Structures. World Scientific, Singapore.
- Sumer, B.M., Fredsoe, J., 2002. The Mechanics of Scour in the Marine Environment. World Scientific, Singapore.
- Sumer, B.M., Fredsoe, J., Gravesen, H., Bruschi, R., 1989. Response of marine pipelines in scour trenches. *J. Waterw. Port. Coast. Ocean. Eng.* 4 (477), 477–496. [https://doi.org/10.1061/\(ASCE\)0733-950X\(1989\)115](https://doi.org/10.1061/(ASCE)0733-950X(1989)115).
- Sumer, B.M., Truelsen, C., Sichmann, T., Fredsoe, J., 2001. Onset of scour below pipelines and self-burial. *Coast. Eng.* 42 (4), 313–335.
- Swindell, R., Belfroid, S., 2007, January. Internal flow induced pulsation of flexible risers. In: Offshore Technology Conference. Offshore Technology Conference.
- Teh, T.C., Palmer, A.C., Damgaard, J.S., 2003. Experimental study of marine pipelines on unstable and liquefied seabed. *Coast. Eng.* 50 (1), 1–17.
- Thethi, R., Howells, H., Natarajan, S., Bridge, C., 2005, January. A fatigue monitoring strategy and implementation on a deepwater top tensioned riser. In: Offshore Technology Conference. Offshore Technology Conference.
- Wagner, D.A., Murff, J.D., Brennodden, H., Sveggen, O., 1989. Pipe-soil interaction model. *J. Waterw. Port. Coast. Ocean. Eng.* 115 (2), 205–220.
- Waloen, A.O., Benjaminsen, J.T., Brown, N., Due-Andresen, S., Stafford, M., 1993. Fatigue, internal stresses and deformations of electrical umbilicals: analytical work. *Int. J. Offshore Polar Eng.* 3 (02).
- Zhao, M., Cheng, L., 2010. Numerical investigation of local scour below a vibrating pipeline under steady currents. *Coast. Eng.* 57 (4), 397–406.
- Zheng, H., Price, R., Modarres-Sadeghi, Y., Triantafyllou, M.S., 2012, January. A systematic approach to understanding the influence of high-harmonic and chaotic vortex induced vibrations on fatigue damage of flexible risers. In: The Twenty-second International Offshore and Polar Engineering Conference. International Society of Offshore and Polar Engineers.